

## FK SERIES

# ROTATING PULVERIZER WITH KIT FRANTUMATORE GIREVOLE CON KIT

**HARDOX®**  
IN MY BODY

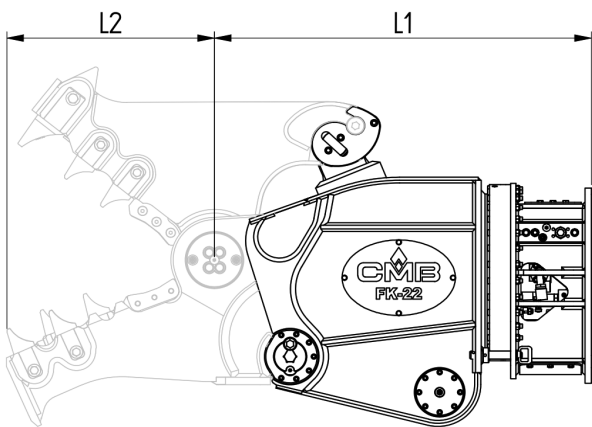
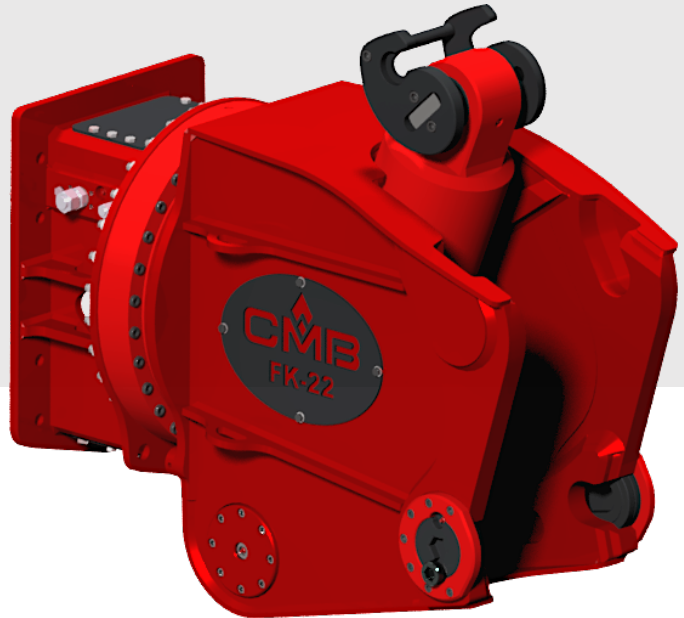

Drain line advised  
Drenaggio consigliato

FK SERIES		FK 10	FK 16	FK 22	FK 30	FK 40
EXCAVATOR WORKING PRESSURE	bar	300-350	350	350	350	350-400
EXCAVATOR OIL FLOW	l/min	200-250	250	250	300	350-450
L1	mm	1250	1380	1440	1500	1650
ROTATION WORKING PRESSURE	bar	120	120	120	120	140
ROTATION OIL FLOW	l/min	10	20	20	20	40
SPEED VALVE	SPEED VALVE	OPT	OPT	YES	YES	YES

### FK SERIES + FH KIT



### FK SERIES + CC KIT



### FK SERIES + CR KIT



Attachment-excavator couplings data are for information only, always check load diagram of the machine.

8 I dati relativi agli accoppiamenti attrezzatura-escavatore sono da considerarsi puramente indicativi, controllare sempre i diagrammi di carico della macchina operatrice.

➤ **ROBUST FRAME IN HARDOX 450**  
STRUTTURA ROBUSTA IN HARDOX 450

➤ **QUICK KIT CHANGE**  
KIT CHELE IN AGGANCIAMENTO RAPIDO

➤ **MULTI PURPOSE WITH INTERCHANGEABLE JAWS**  
VERSATILITÀ CON CHELE INTERCAMBIABILI

➤ **INTERCHANGEABLE TEETH**  
DENTI INTERCAMBIABILI

Innovative, versatile, robust and fast, we simply put our new product composed of a main body which can change quickly the kits can deal with the different situations of the building site.

- > 2times reversible blades
- > 360° continuous hydraulic rotation
- > Inverted mounted cylinder
- > Speed Valve



Innovativo, versatile, robusto e veloce, in poche parole il nostro nuovo prodotto composto da un corpo attrezzatura al quale poter cambiare in modo rapido i kit può affrontare le diverse situazioni del cantiere.

- > Lama 2profili
- > Rotazione idraulica a 360°
- > Cilindro completamente protetto e rovesciato
- > Valvola di velocità

## FH KIT

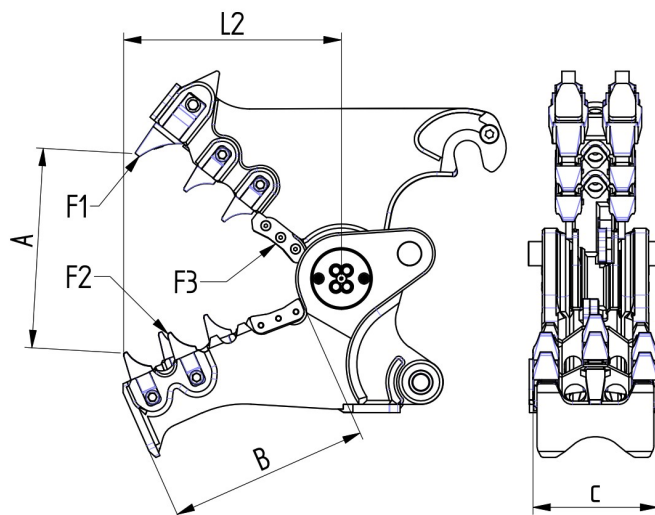
**DEMOLITION KIT**  
KIT DEMOLIZIONE



FH KIT		FK 10	FK 16	FK 22	FK 30	FK 40
BODY WEIGHT	kg	875	1200	1320	1900	2250
 KIT WEIGHT	kg	615	800	1145	1490	1720
TOTAL WEIGHT	kg	1490	2000	2465	3390	3970
 EXCAVATOR WEIGHT	ton	10 - 17	17 - 24	23 - 35	33 - 48	45 - 55
L2	mm	770	802	820	980	1070
L1+L2	mm	2020	2227	2290	2480	2720
A	mm	550	670	790	900	1020
B	mm	620	720	750	840	910
C	mm	415	450	480	550	600
 BLADE	mm	120	195	195	300	300
F1	ton	60	80	95	110	135
F2	ton	100	130	140	180	200
F3	ton	150	200	310	340	400

# FK SERIES



**HARDOX®**  
IN MY BODY

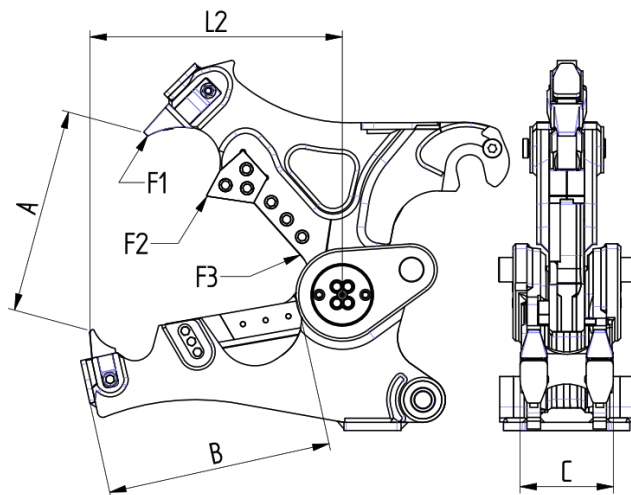

## CC KIT

COMBI KIT  
KIT COMBI



CC KIT		FK 10	FK 16	FK 22	FK 30	FK 40
BODY WEIGHT	kg	875	1200	1320	1900	2250
 KIT WEIGHT	kg	725	900	1085	1490	2000
TOTAL WEIGHT	kg	1600	2100	2405	3390	4250
 EXCAVATOR WEIGHT	ton	10 - 17	17 - 24	23 - 35	33 - 48	45 - 55
L2	mm	870	995	1130	1220	1330
L1+L2	mm	2120	2375	2600	2720	2980
A	mm	510	670	780	870	980
B	mm	770	800	830	950	1020
C	mm	315	340	380	410	450
 BLADE	mm	420	510	605	675	750
F1	ton	55	80	95	120	150
F2	ton	85	110	140	180	210
F3	ton	260	420	580	660	800

Attachment-excavator couplings data are for information only, always check load diagram of the machine.

10 I dati relativi agli accoppiamenti attrezzatura-escavatore sono da considerarsi puramente indicativi, controllare sempre i diagrammi di carico della macchina operatrice.





**CR KIT**

**SHEAR KIT  
KIT CESOIA**

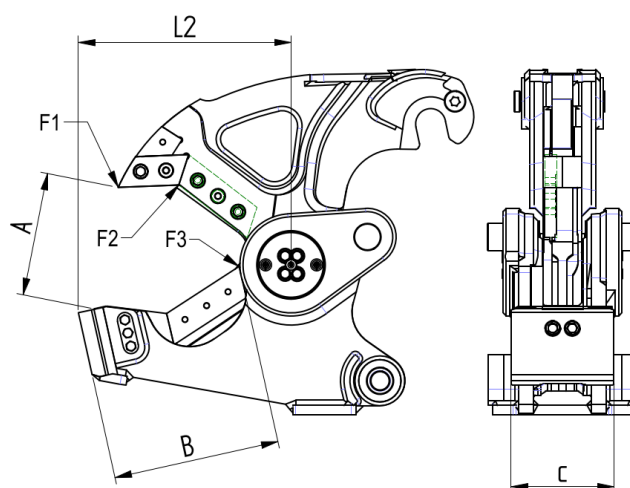

CR KIT		FK 10	FK 16	FK 22	FK 30	FK 40
BODY WEIGHT	kg	875	1200	1320	1900	2250
 KIT WEIGHT	kg	665	850	1070	1490	1850
TOTAL WEIGHT	kg	1540	2050	2390	3390	4100
 EXCAVATOR WEIGHT	ton	10 - 17	17 - 24	23 - 35	33 - 48	45 - 55
L2	mm	650	680	710	840	940
L1+L2	mm	1900	2105	2180	2340	2590
A	mm	320	380	460	520	575
B	mm	420	520	560	620	700
C	mm	300	330	350	400	430
 BLADE	mm	400	480	530	580	620
F1	ton	70	100	140	160	210
F2	ton	110	160	240	325	400
F3	ton	185	300	520	660	715

Attachment-excavator couplings data are for information only, always check load diagram of the machine.

I dati relativi agli accoppiamenti attrezzatura-escavatore sono da considerarsi puramente indicativi, controllare sempre i diagrammi di carico della macchina operatrice.